

SOLIS MASTER 5000

Digital

Technische Dokumentation
Technical Documentation
Documentation technique



SOLIS Ltd SOLIS-House CH-8152 Glattbrugg	SOLIS MASTER 5000 Digital ET-Master 5000 Digital_D 19.06.02 MIO	D	Page 1 of 12
		11.06.02	

Drawing 1 / Zeichnung 1

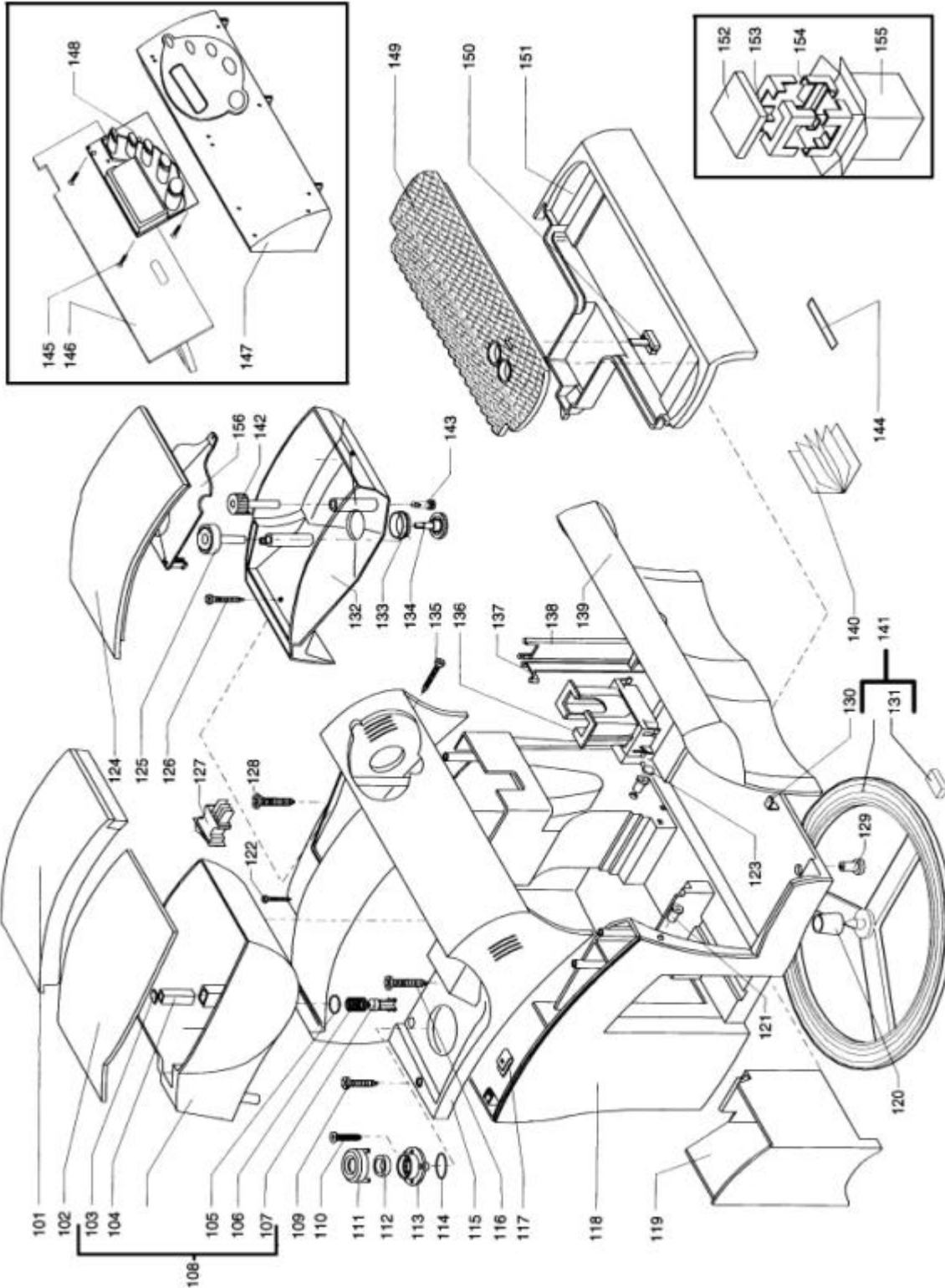

SOLIS Ltd SOLIS-House CH-8152 Glattbrugg	SOLIS MASTER 5000 Digital ET-Master 5000 Digital_D 19.06.02 MIO	D	Page 2 of 12
		11.06.02	

Pos.	Part. no.				Sp set
Pos.	Artikel-Nr.	Bezeichnung deutsch	Description francais	Description english	ET set
.	9190.29	Schraubenzieher Torx T 15	tourne vis Torx T 15	screw-driver Torx T 15	1
.	9190.30	Bit Tri Wing	bit Tri Wing	bit Tri Wing	1
101	2502.00	Deckel zu Tassenablage	couvercle du receptacle tasses	Cover for cup storage	
102	2502.05	Deckel zu Wassertank grau	couvercle du reser. d'eau gris	Cover for water reservoir	
103	2400.50	Schwimmer-Deckel	couvercle du floteur	swimmer cover	
104	2400.51	Schwimmer	floteur	swimmer	
105	2400.38	O-Ring Orm 0060-303 Silikon schwarz	or-orm 0060-30	O-ring ORM 0060-303 Silicone black	
106	2400.39	Feder zu Wassertank	ressort p. recip. d'eau	Spring water reservoir	
107	2400.40	Ventilzapfen	bouchon de valve	Seal retainer, grey	
108	2503.99	Wassertank kompl. mit Schwimmer	réservoir d'eau	water reservoir	
109	2502.15	Schraube Tcb 3.5 x 22	vis tcb 3.5 x 22	Screw, TCB 3.5 x 22	
110	2502.16	Schraube 3.5 x 9.5	vis 3.5 x 9.5	Screw, 3.5 x 9.5	
111	2400.41	Kappe zu Ventil	chape de valve	Valve cap	
112	2400.42	Dichtung Gaco Dim 14	joint gaco dim 14	Seal	
113	2502.17	Dichtungsbehälter grau	porte-joint gris	Seal retainer, grey	
114	2502.18	Sicherheitsdichtung	joint de securite	Safety seal	
115	2503.91	Gehäuse-Oberteil Digital silber	partie sup. du boitier argent	top cover Digital silver	
115	2505.37	Gehäuse OT silber , Schrift schwarz	Partie supp. argent, écriture noir	Upper housing silver, print black	
116	2502.48	Schraube Tcb 3.5 x 45	vis tcb 3.5 x 45	Screw, TCB 3.5 x 45	
117	2403.05	Klammer zu Bohnenbehälter	crochets p. recipient a grains	Screw retainer	
118	2503.85	Gehäuse grau RAL7016	boitier gris RAL7016	housing grey RAL7016	
119	2503.86	Satzbehälter kompl. grau RAL7016	bac de marc de cafe compl. gris RAL7016	waste container compl. grey RAL7016	
120	2505.03	Büchse zu Drehring			
122	2502.15	Schraube Tcb 3.5 x 22	vis tcb 3.5 x 22	Screw, TCB 3.5 x 22	
124	2502.40	Deckel Bohnenbehälter grau	couv. du bac des grains gris	Cover for bean container, grey	
125	2502.45	Regulierknopf Mahlfineinheit	bouton de regl. du mouture	Grinder adjustment knob	
126	2502.46	Schraube Tcb 3.5 x 50.8	vis tcb 3.5 x 50.8	Screw, TCB 3.5 x 50.8	
127	2502.47	Hauptschalter	interrupteur principal	Master switch	
128	2502.48	Schraube Tcb 3.5 x 45	vis tcb 3.5 x 45	Screw, TCB 3.5 x 45	
129	2502.36	Gerätekuss schwarz	ped de l'appareil noir	Appliance foot, black	
130	2502.49	Winkel zu Türverschluss	corniere de fermeture de porte	Angle for door closure	
131	2400.34	Fuss zu Drehring	ped p. bague tournante	Rubber foot for rotating ring	
132	2502.50	Bohnenbehälter grau	reserv. des grains de cafe gr.	Coffee bean container, grey	
133	2502.51	Dämpfungsgummi zu Bohnenbehälter	caoutch. amorti. de reservoir	Rubber ring	
134	2502.52	Zahnrad zu Mahlgradverstellung	pignon	Cog wheel	
135	2502.53	Schraube Tcb 3.5 x 16	vis tcb 3.5 x 16	Screw, TCB 3.5 x 16	
136	2504.17	Auslauf kompl. mit Support	Ecoulement avec support	Dispensing head with support	
137	2502.59	Türscharnier lang	charniere de porte long	Door hinge, long	
138	2502.60	Türscharnier kurz	charniere de porte court	Door hing, short	
139	2503.87	Türe silber	porte gris	door silver	
139	2505.38	Türe silber, Schrift schwarz	porte argent, écriture noir	Door silver, print black	
140	0001.25	Bedienungsanleitung Master 5000 Digital	mode d'emploi master 5000 digital	manual	

Pos.	Part. no.				Sp set
Pos.	Artikel-Nr.	Bezeichnung deutsch	Description francais	Description english	ET set
141	2400.22	Drehring	bague tournante	Rotating ring	
142	2503.95	Verstellrad Mengeneinstellung	bouton de réglage du café	knob for coffee adjustment	
143	2503.96	Zahnrad Mengeneinstellung	pignon réglage du café	gear wheel for coffee adjustm. knob	
145	2502.72	Schraube Tcb 3 x 12	vis tcb 3 x 12	Screw, TCB 3 x 12	
146	2503.93	Steuerprint Digital 230V	commande électronique 230V	control box Digital 230V	
146	2504.31	Steuerprint 100 - 120 Volt M5000 Digital		control unit M 5000 Digital 100-120volts	
147	2503.92	Bedienfeld Digital silber	champ de commande argent	keybord Digital	
148	2503.94	Tastaturprint Digital	champ de commande digital	PCB for keyboard Digital	
149	2502.75	Abtropfrost grau	grille d'égouttage gris	Cup tray, grey	
150	2502.78	Schwimmer rot	flotteur rouge	Float, red	
151	2502.81	Abtropfschale grau RAL7016	coupelle d'égouttage gris RAL7016	Drip tray, grey RAL7016	
152	2503.06	Deckeinlage Styropor-Verpackung	couche de styropor emballage	Styrofoam packaging insert for top	
153	2503.07	Styropor-Einsatz oben	insert de styropor en haut	Upper Styrofoam packaging insert	
154	2503.08	Styropor-Einsatz unten	insert de styropor en bas	Lower Styrofoam packaging insert	
155	2504.18	Aussenschachtel Master 5000 Digital	Carton master 5000 digital	Outer carton for Master 5000 digital	

Drawing 2 / Zeichnung 2

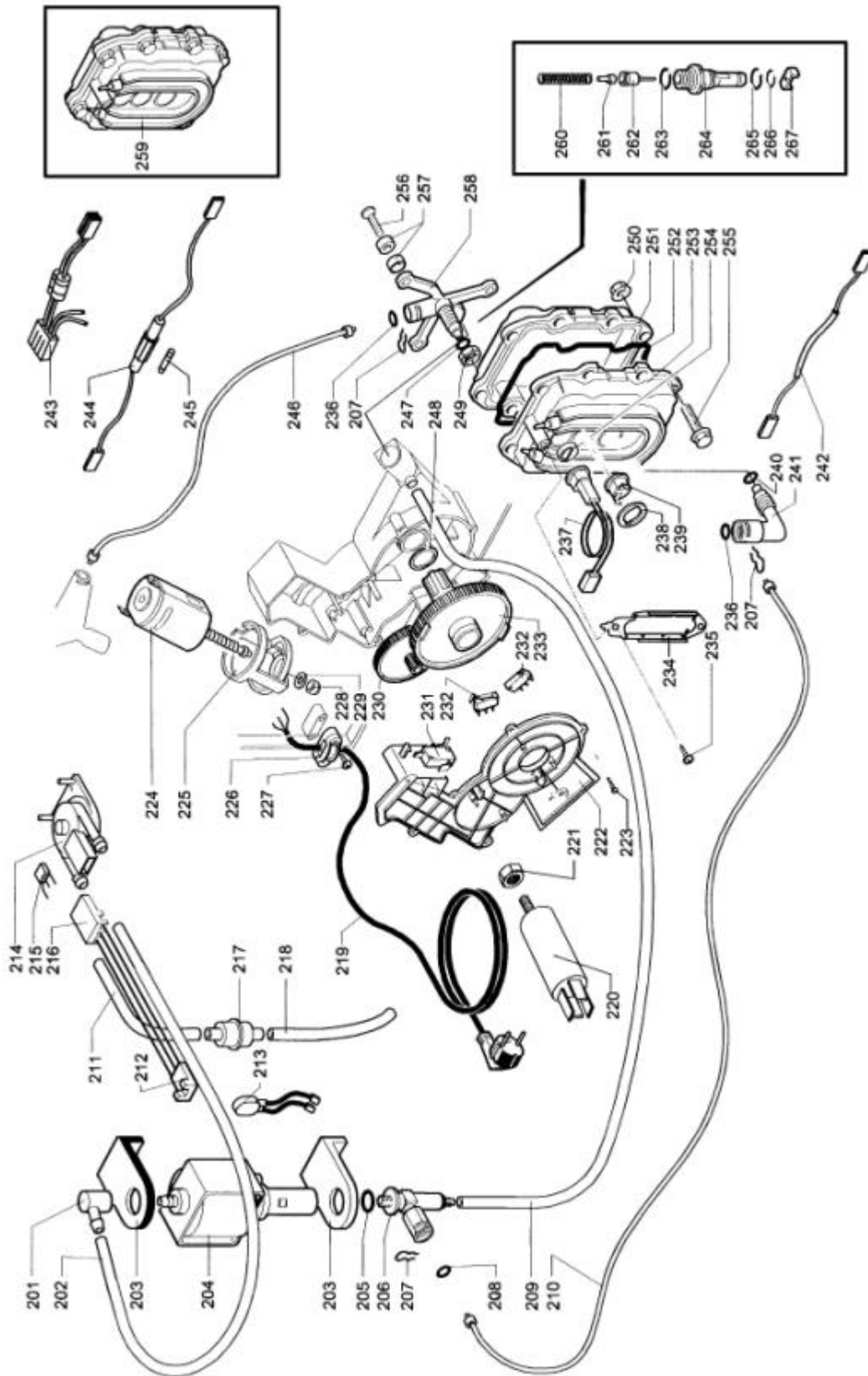

SOLIS Ltd SOLIS-House CH-8152 Glattbrugg	SOLIS MASTER 5000 Digital ET-Master 5000 Digital_D 19.06.02 MIO	D	Page 5 of 12
		11.06.02	

Pos.	Part. no.				Sp set
Pos.	Artikel-Nr.	Bezeichnung deutsch	Description francais	Description english	ET set
201	2401.22	Gummi Raccord 90 Grad	raccord en gomme 90 degre	Angled rubber connector	
202	2503.10	Silikon-Schlauch L = 120 mm 5x8	tuyau de silicone l = 120 mm 5x8	Silicone tube 5 x 8 / 13 cm	
203	2503.11	Pumpenaufhängung	suspension de la pompe	Pump support	
204	2390.92	Pumpe EX5 230V	pompe ex5 230V	Pump EX5 230V	
204	2504.21	Pumpe Ulka 100V	pompe Ulka 100V	pump Ulka 100V	
204	2504.22	Pumpe Ulka 120V	pompe Ulka 120V	pump Ulka 120V	
205	2391.23	Dichtung zu Sicherheitsventil		O-ring, 2031	
206	2503.12	Sicherheitsventil kompl. D=8	soupape de surete compl. d=8	Safety valve, complete, D = 8	
207	2503.13	Klemmfeder	ressort de blocage	Spring clip	
208	2503.14	O-Ring 2015	joint torique 2015	O-ring, 2015	
209	2503.15	Silikon-Schlauch L = 290 mm 5x8	tuyau de silicon l = 290 mm 5x8	Silicone tube 5 x 8 / 30 cm	
210	2503.16	Druckschlauch mit Raccord	tuyau de pressin avec raccord	Pressure hose with connector	
211	2503.18	Silikon-Schlauch L = 90 mm 5x10	tuyau de silicone l = 90 mm 5x10	Silicone tube 5 x 8 / 5 cm	
213	2503.20	Kabel Gelb Klixon	cable klixon jaune	Cable yellow Klixon	
214	2503.17	Turbine kompl.	turbine compl.	Turbine, complete	
217	2390.85	Wasserfilter	500 filtre d'eau	Suction filter	
218	2503.21	Silikon-Schlauch L = 120 mm 5x10	tuyau en silicon l = 120 mm 5x10	Silicone tube 5 x 8 / 10 cm	
219	2401.48	Anschlusskabel CH	cablage CH	Connecting cable CH	
219	2504.28	Kabel schwarz Schuko	cable	power cord black schuko	
220	2503.22	Netzfilterprint 230 V	carte reseau du filtre	Mains filter PCB	
220	2503.97	Entstörfilter	filtre anti parasite	noise filter	
221	2503.98	Mutter zu Entstörfilter	écrou pour filtre anti parasite	nut for noise filter	
222	2503.23	Deckel grau zu Getriebe	couvercle d'engrenage gris	Mechanism lid, grey	
223	2502.53	Schraube Tcb 3.5 x 16	vis tcb 3.5 x 16	Screw, TCB 3.5 x 16	
224	2401.50	Getriebemotor kompl. 33V	moteur principal complet 33V	Geared motor with endless screw 33V	
225	2401.51	Schwingungsdämpfer	etouffeur	Rubber bearing for geared motor	
226	2503.24	Zugentlastungsbride	bride de detente de traction	Cord grip	
227	2502.53	Schraube Tcb 3.5 x 16	vis tcb 3.5 x 16	Screw, TCB 3.5 x 16	
228	2401.55	Lager	depot	Porous bearing for geared motor	
229	2401.54	Unterlagscheibe D 5,5	rondelle d 5,5	Bakelite washer for geared motor	
230	2401.52	Schneckenrad ZE	roue helicoidale	Worm gear wheel, grey	
231	2503.25	Mikroschalter	microinterrupteur	Micro-switch	
232	2401.58	Mikroschalter Getriebe Xch5-81	interrupteur miniature command	Micro-switch	
233	2502.54	Antriebsrad	roue d'entrainement	Drive wheel	
234	2503.27	Thermostat-Haltesfeder	ressort de compression	Pressure spring	
235	2400.83	Blechschaube M5x8	vis m5x8	Screw M6 x 10	
236	2503.14	O-Ring 2015	joint torique 2015	O-ring, 2015	
237	2503.29	Sensor kompl.	detecteur compl.	Sensor, complete	
238	2392.91	Rondelle für Thermostat	rotonde thermostat	thermostat	
239	2401.37	Thermostat 150°	thermostat 150 degre	thermostat 150°	
240	2390.63	O-Ring klein zu Stutzen	o-ring pet. p soutien	O-ring, 2018 silicone	
241	2503.30	Schnellverschluss	fermeture rapide	Quick-acting closure	
242	2503.31	Kabel mit Thermosicherung	cable avec thermofusible	Cable with thermal circuit breaker	
243	2503.44	Anschlusskabel Getriebemotor	cable de raccord du motoreduc.	Connecting cable for geared motor	

Pos.	Part. no.				Sp set
Pos.	Artikel-Nr.	Bezeichnung deutsch	Description francais	Description english	ET set
245	2403.10	Sicherung 6.3A	fusible 6.3A	fuse 6.3A	
246	2503.32	Druckschlauch 2 x 4 L=440	tuyau de pression 2 x 4 l=440	Pressure hose, 2 x 4 L=440	
247	2390.63	O-Ring klein zu Stutzen	o-ring pet. p soutien	O-ring, 2018 silicone	
248	2403.17	Kunststoffunterlage	support plastique	Plain washer	
249	2503.33	Mutter 1/8"	ecrou 1/8"	Nut, 1/8"	
250	2503.34	Mutter M6	ecrou m6	Nut, M6	
252	2503.36	Dichtung zu Heizung	joint du systeme de chauffage	Seal for heating element	
254	2403.13	Aluminium-Ring	anneau an aluminium	Spacer	
255	2503.38	Schraube M 6 x 26	vis m 6 x 26	Screw, M6 x 26	
256	2503.40	Schraube Tspc M 5 x 20	vis tcb m 6 x 20	Screw TSPC M5 x 20	
257	2503.41	Isolations-Distanzscheibe	rondelle d'ecartement isolante	Insulating spacer	
258	2503.48	Hebel zu Mikroschalter-Tresterbehälter	levier de micr. du traitem. marc	Lever for micro-switch - used grounds cont.	
259	2503.39	Boiler kompl. eloxiert 230V dünnwandig	chauffe-eau compl. elox. 230V	Boiler complete elox. 230V	
259	2504.19	Boiler kompl. eloxiert 230V dickwandig M 5000 Digital	Chauffe-eau compl. elox. 230V M 5000 digital	Boiler compl. elox. 230V M 5000 Digital	
259	2504.23	Boiler kompl. 100V	chauffe - eau compl. 100V	boiler compl. 100V	
259	2504.24	Boiler kompl. 120V	chauffe - eau compl. 120V	boiler compl. 120V	
260	2503.43	Feder zu Zapfen	ressort de tourillon	Spring for nozzle	
261	2402.20	Adapter zu Supportventil	adapteur pour soupape support	Adapter for sliding valve	
262	2402.17	Ventilstift	soupape support	valve support	
263	2400.80	O-Ring orm 0080-20 Silikon	or m 0100-15 silicon	O-ring, 80.20	
264	2402.16	Ventilzapfen	bouchon de valve	Valve nozzle	
265	2400.77	O-Ring orm 0090-20 epdm	or m0090-20	O-ring 90-20	
266	2400.76	O-Ring orm 0050-20 epdm	or m 0050-20 epdm	O-ring 50-20	
267	2402.18	Plättchen	plaquette	Plate	

Drawing 3 / Zeichnung 3

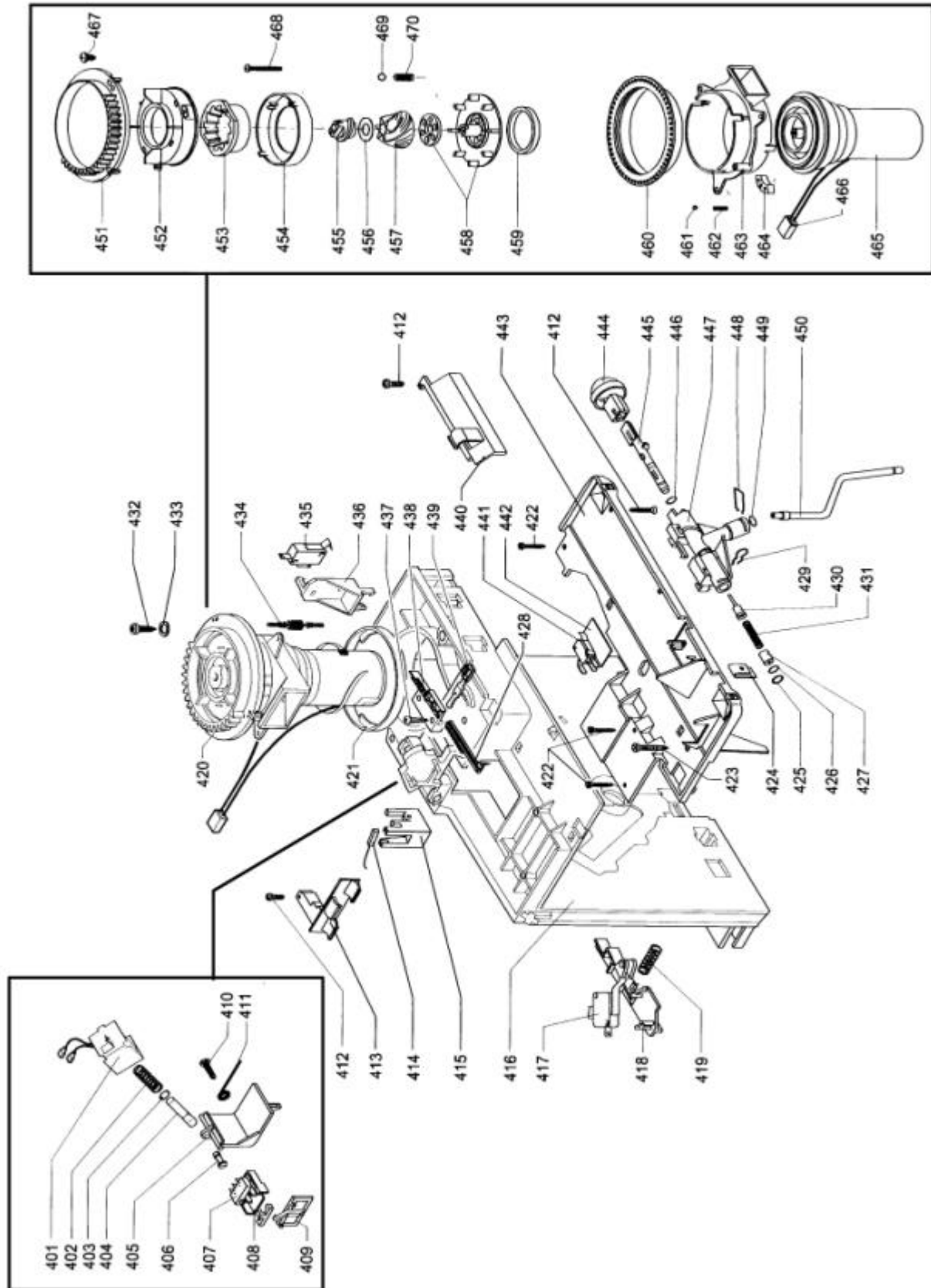

SOLIS Ltd SOLIS-House CH-8152 Glattbrugg	SOLIS MASTER 5000 Digital ET-Master 5000 Digital_D 19.06.02 MIO	D	Page 8 of 12
		11.06.02	

Pos.	Part. no.				Sp set
Pos.	Artikel-Nr.	Bezeichnung deutsch	Description francais	Description english	ET set
401	2504.12	Dosierspule 230 Volt		dosing coil 230 Volt	
401	2504.20	Dosierspule 100 - 120 Volt	bobine d' induction	dosing coil 100 - 120 volts	
402	2401.89	Feder zu Dosierer	ressort p. dosateur	Pressure spring for proportioning electrom.	
403	2401.90	Scheibe 7 Uni 7434	disque 7 uni 7434	Absorption ring	
404	2401.91	Anker	ancree	Anchor	
405	2401.98	Klappe	trappe	Proportioning flap, grey	
406	2401.97	Bolzen zu Anker	goujon pour ancre	Pin for proportioning flap	
407	2401.92	Mikroschalter Xch 5-81	interrupteur xch 5-81	Proportioning micro-switch	
408	2401.93	Verstellteil	mecanisme de changement	Support for proportioning micro-switch	
409	2401.94	Schaltstück	distributeur	Contacteur	
410	2400.73	Blechschrabe Tcb 3.0x12 Din	vis tcb 3.0x12 din 7505 b dnp	Screw, TCB 3 x 12	
411	2401.96	Abstreifer	devetisseur	Stripper	
412	2400.73	Blechschrabe Tcb 3.0x12 Din	vis tcb 3.0x12 din 7505 b dnp	Screw, TCB 3 x 12	
413	2503.45	Kabelhalterung	porte-cable	Cable holder	
414	2504.00	Reedsensor	interrupteur reed	reed switch	
415	2504.01	Reedsensorhalter	support interrupteur reed	holder for reed switch	
416	2503.46	Montageplatte	plaque de montage	Mounting plate	
417	2503.47	Mikroschalter	microinterrupteur	Micro-switch	
418	2503.48	Hebel zu Mikroschalter-Tresterbehälter	levier de micr. du traitem. marc	Lever for micro-switch - used grounds cont.	
419	2503.49	Feder	ressort	Spring	
420	2503.50	Mahlwerk kompl. 230V	mencanisme du moulin compl. 230V	Grinder complete, 230V	
420	2504.26	Mahlwerk kompl. 100V	moulin compl. 100V	grinder compl. 100V	
420	2504.27	Mahlwerk kompl. 120V	moulin compl. 120V	grinder compl. 120V	
421	2503.51	Verstärkungsring zu Mahlwerk	rondelle de renfort de mecan.	Reinforcing ring for grinder	
422	2502.53	Schraube Tcb 3.5 x 16	vis tcb 3.5 x 16	Screw, TCB 3.5 x 16	
423	2503.60	Schraube Tcb 3.5 x 50.8	vis tcb 3.5 x 50.8	Screw, TCB 3.5 x 50.8	
425	2503.52	O-Ring 3.85 x 1.9	joint torique 3.55 x 1.9	O-ring 3.85 x 1.9	
426	2503.14	O-Ring 2015	joint torique 2015	O-ring, 2015	
427	2503.53	Federhalterung	support du ressort	Spring holder	
428	2504.14	Schlitten zu Kaffeemengenregulierung			
429	2503.13	Klemmfeder	ressort de blocage	Spring clip	
430	2402.17	Ventilstift	soupape support	valve support	
431	2503.43	Feder zu Zapfen	ressort de tourillon	Spring for nozzle	
434	2503.54	Antivibration Fuer Mahlwerk	dispositif antri. du mecan.	Anti-vibration arrangement for grinder	
435	2503.47	Mikroschalter	microinterrupteur	Micro-switch	
436	2503.55	Mikroschalter-Halterung	support du microinterrupteur	Micro-switch holder	
437	2505.01	Schraube TCB 3,5x12	vis TCB 3,5x12	Screw TCB 3,5x12	
438	2504.15	Arretierbügel für Dosierverstellhebel			
439	2503.56	Dosierverstellhebel	levier de dosage réglable	Proportioning adjustment lever	
440	2503.57	Kabelhalterung	levier de dosage réglable	Cable holder	

Pos.	Part. no.				Sp set
Pos.	Artikel-Nr.	Bezeichnung deutsch	Description francais	Description english	ET set
441	2503.61	Mikroschalter	microinterrupteur	Micro-switch	
442	2503.58	Plättchen für Türmikroschalter	plaquette de microinter. porte	Plate for door micro-switch	
443	2503.59	Trägerplatte schwarz	plaque support	Bearer plate	
444	2503.63	Drehknopf grau	bouton tournant gris	Rotary knob, grey	
445	2503.68	Heisswasserspindel	broche d'eau chaude	Hot water spindle	
447	2503.70	Dampfhahn	robinet de vapeur	steam wand	
448	2503.71	Feder zu HW-/Dampfrohr	ressort du tube d'eau / vapeur	Spring for hot water/steam tube	
449	2401.10	O-Ring orm 0060-20 Epdm	orm 0060-20 epdm	O-ring 60-20	
451	2503.73	Regulerring	regulation	Regulator	
452	2401.65	Mahlringaufnahme	reception du disque de mouture	Grinding ring retainer	
453	2401.66	Mahlring/Mahlkegel Kompl.	disque de mouture/disque compl	Grinding ring/ cone compl.	
454	2401.67	Mahlringabdeckung	recouvrement du disque de mout	Grinding ring cover	
455	2503.74	Schnecke für Kegel	vis de roue conique	Endless screw for cone	
456	2401.29	Pass-Scheibe 10 x 16 x 0.2	disque 10 x 16	Plain washer, 10 x 16 x 0.1	
457	2401.66	Mahlring/Mahlkegel Kompl.	disque de mouture/disque compl	Grinding ring/ cone compl.	
458	2403.14	Trägerscheibe mit Stahlring	disque portante	Support washer with steel ring	
459	2402.55	Filzring	rondelle	Felt washer	
460	2401.72	Verstellring	rondelle	Adjusting ring	
461	2402.64	Stahlkugel D 3.2 Inox	boule	ball 3.2 Inox	
462	2402.63	Feder zu Kugel	ressort p. helice	Spring for steel ball, D=3.2	
463	2402.52	Motor Support	support moteur	Motor support	
464	2403.15	Dämpfungsgummi Mahlwerk	gomme amortissement p. moulin	Rubber vibration absorber for grinder	
465	2403.16	Mahlwerksmotor kompl. 230 V	moteur moulin	grinder motor compl. 230 V	
466	2503.75	Kabel kompl. 2polig	cable bipolaire compl.	Cable, complete, 2-core	
467	2503.76	Blechschraube 2.9 x 6.5	vis a tole 2.9 x 8.5	Self-tapping screw, 2.9 x 6.5	
468	2401.70	Schraube 3,5x48	vis 3,5x48	Screw	
469	2402.60	Stahlkugel D 5.5 Inox	boule d 5.5 inox	Steel ball, D=3.2	
470	2402.54	Feder zu Trägerscheibe	ressort p. helice	Spring for support washer	

Drawing 4 / Zeichnung 4

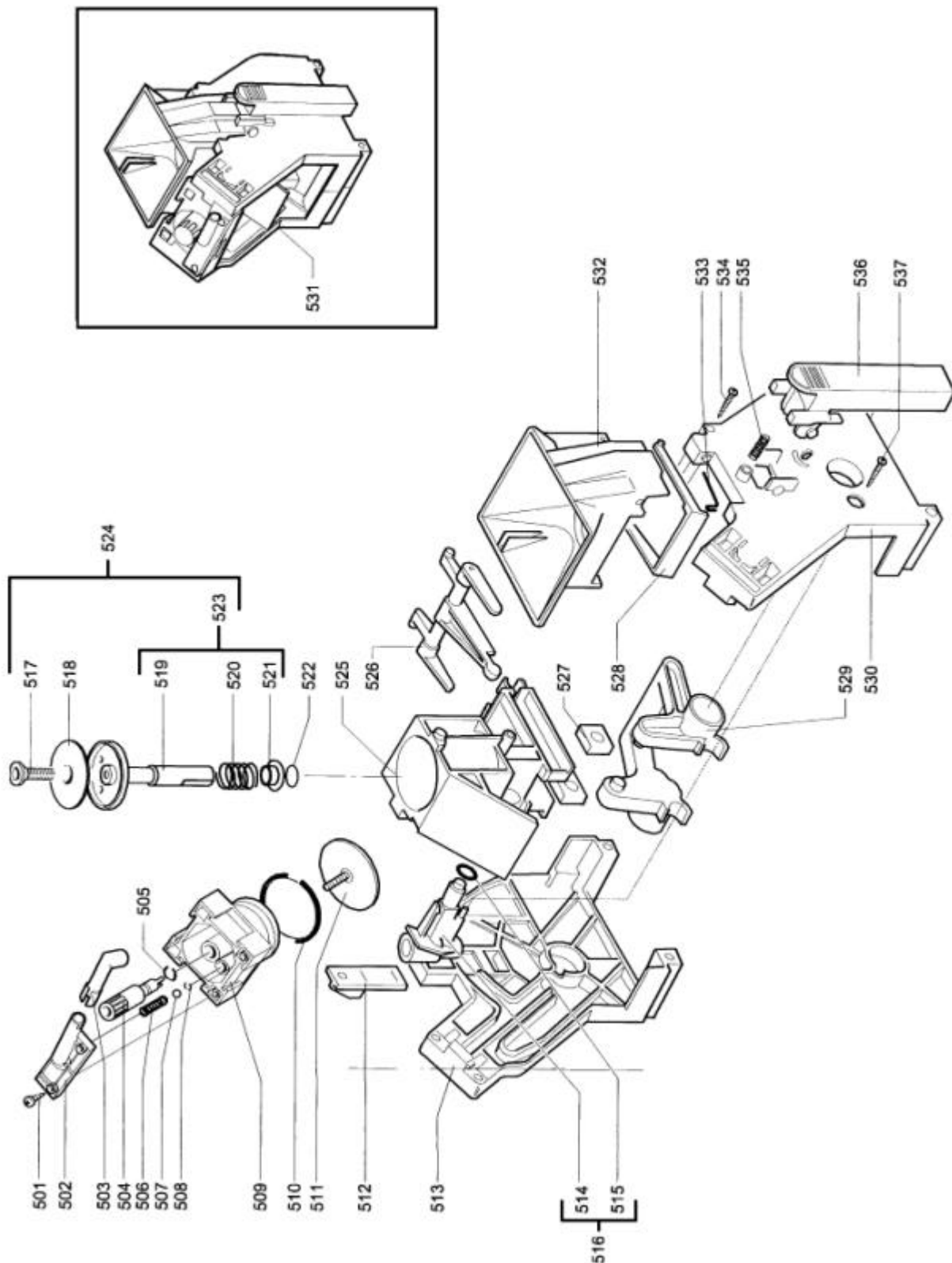

SOLIS Ltd SOLIS-House CH-8152 Glattbrugg	SOLIS MASTER 5000 Digital ET-Master 5000 Digital_D 19.06.02 MIO	D	Page 11 of 12
		11.06.02	

Pos.	Part. no.				Sp set
Pos.	Artikel-Nr.	Bezeichnung deutsch	Description francais	Description english	ET set
.	2402.91	Schlüssel zu Sieb	Cle de filtre	Sieve tool	
.	0977.09	Reinigungs-Pinsel	Pinceau de nettoyage	Cleaning brush	
501	2402.23	Blechschraube Tcb 3.0x10 Din	vis tcb 3.0x10 din	Screw, TCB 3 x 10	
502	2503.77	Anlauf -Flansch	bride de demarrage	Inlet flange	
503	2503.78	Auslaufrohr	tube d'ecoulement	Outlet pipe	
504	2402.24	Schraubmutter für Ze	ecrou pour unite centrale	Nut for central unit	
505	2402.25	O-Ring R5 Epdm	or r5 epdm	O-ring R5	
506	2503.79	Feder Ventil ZE	ress. du soup. de l'untie cen.	Spring valve, central unit	
507	2401.32	Gummidichtung zu Kolbenventil	joint en gomme	Rubber seal for plunger valve	
508	2401.95	O-Ring orm 0090-15 Epdm	or orm 0080-15 epdm	O-ring 80-15	
509	2402.27	Kolben	piston	Piston	
510	2402.28	O-Ring orm 0320-40 Epdm	or orm 0320-40 epdm	O-ring 032040	
511	2503.80	Sieb oben mit Schraube D=35.8	tamis super. avec vis d=35.8	Sieve, upper, with screw D=35.8	
512	2402.30	Verschluss	fermeture	Closure	
513	2402.31	Platte hinten	plaque arriere	Panel, rear	
514	2402.32	Ventilkörper	corps de soupape	Valve body	
515	2402.33	O-Ring 2025 Epdm	or 2025 epdm	O-ring 2025	
517	2503.81	Schraube M 3 x 14	vis	Screw	
518	2503.82	Sieb D=35.8	tamis d=35.8	Sieve D=35.8	
524	2403.27	Stössel kompl. mit Sieb neu	pilon compl.	Tappet, complete with sieve	
525	2403.26	Kaffeekammer neu	chambre	Coffee compartment	
526	2402.39	Steuerhebel	cevrier de commande	Control lever	
527	2402.41	Gleiter	glisseur	Slide	
528	2402.43	Kratzer	grattoir	Stripper	
529	2402.42	Kurbelwelle	arbre coude	Crankshaft	
530	2402.47	Platte vorne	plaque avant	Panel front	
531	2503.83	ZE kompl. grau	unite centrale compl. gris	Central unit, complete grey	
532	2402.81	Trichter zu ZE-Press	cone pour zd compresseur	Funnel for central unit press	
533	2401.77	Feder	ressort	Spring	
534	2402.44	Blechschraube 3.5x19	vis 3.5x19	Self-tapping screw, 3.5 x 19 TCB	
535	2402.45	Feder	ressort	Spring	
536	2402.46	Griff	touche	Handle	
537	2401.61	Schraube 2.9x19	vis 2.9x19	Screw, TCB 2.9 x 19	

Elektroschema / Electrical diagram Solis Master 5000 digital

Plan électrique / Elettroschema

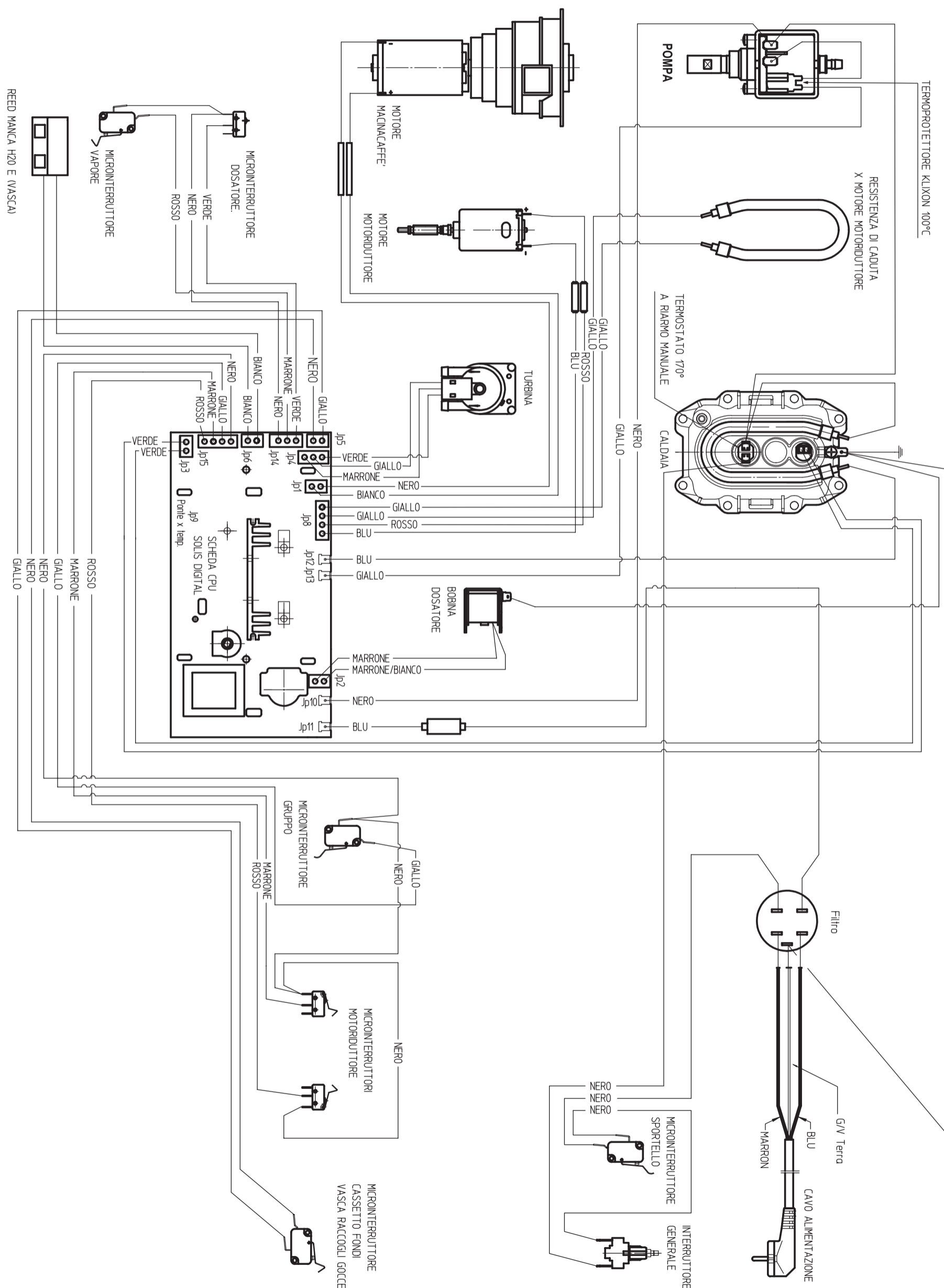







<p>SOLIS Ltd SOLIS-House CH-8152 Glattbrugg</p>	<p>SOLIS Master 5000 digital Elektroschema Master 5000 digital 04.06.02 MIO</p>	<p>A</p>	<p>Page 1 of 2</p>
---	---	-----------------	--------------------

Italiano	Deutsch	English	Francais	
Termoprotettore	Temperatur-sicherung	Thermal protection	Contrôle de température	
Termostato	Sicherheits-thermostat	Safety protection	Contrôle de Sécurité	
Resistenza di caduta x motore motorriduttore	Vorwiderstand Motor	Preresister gear motor	Résistance pour moteur	
Motore motorriduttore	Getriebemotor	Gear motor	Moteur d'engrenage	
Induttanza	Drossel	Impedance coil	Bobine d'impédance	
Macinacaffè	Mühle	Grinder	Moulin	
Bobina dosatore	Spule Dosierer	Coil for doser	Commande	
Sceda cpu	Steuerung	PC- board		
Caldaia	Boiler	Boiler	Corps de chauffe	
Turbina	Turbine	Flowmeter	Debitmetre	
Microinterruttore	Mikroschalter	Micro switch	Micro interrupteur	
Dosatore Vapore	Kaffeedosierer Dampf	Doser coffee Steam tap	Dosage du café vapeur	
Gruppo Motorriduttore	Brüheinheit Getriebe	Brewing group Gear box	unité centrale Engrenage	
Cassetto fondi	Satzbehälter	Waste bucket	Tiroir marc de café	
Sportello	Fronttüre	Front door	Porte	
Interruttore generale	Hauptschalter	Main switch	Interrupteur principale	
Filtro	Netzfilter	Noise filter	Bobine de reseau	
Reed manca aqua	Reed Wassermangel	Reed fresh water tank	Reed contrôle niveau d'eau	
Pompa	Pumpe	Pump	Pompe	
Cavo alimentazione	Netzkabel	Main plug	Câble d'alimentation	
G / V Terra	Gelb / Grün Erde	Yellow / Green GND	Jaune / Vert Terre	
Nero	Schwarz	Black	Noir	
Blu	Blau	Blue	Bleu	
Bianco	Weiss	White	Blanc	
Marrone	Braun	Brown	Marron	
Rosso	Rot	Red	Rouge	
Arrancio	Orange	Orange	Orange	
Verde	Grün	Green	Vert	
Giallo	Gelb	Yellow	Jaune	

Testmodus, SOLIS Master 5000 Digital

Testmodus

1. Maschine **AUS**
2. S3 + S5 halten
3. Maschine **EIN**

	S1	S2	S3	S4	S5
Taste					
	Brüheinheit AUF ↑	Brüheinheit AB ↓	Mühle	Kaffeedosierer	
 S5		Heizung	Pumpe	Temperatur	

Tastentest

Taste drücken, die entsprechende Nummer wird im Display angezeigt. (zweite Linie)

1 2 3 4 5

Inputtest (Mikroswitch, Flowmeter etc.)

1. Brühgruppe oben
2. Brühgruppe unten
3. Kaffeedosierer
4. Heisswasserventil
5. Satzschublade, Tropfschale
6. Brühgruppe eingesetzt
7. Niveausensor Wassertank
8. Flowmeter

1 2 3 4 5 6 7 8

Pumpentest

1. Wasserventil öffnen
 2. S5 + S3 drücken
- Displayanzeige (ca. 40-60) Pumpe O.K.

4567

3 5

50

Mahlwerk - Durchgangstest

(125-130) Mahlwerk O.K.

567

130

Diagnosemodus, SOLIS Master 5000 Digital

Tastenfunktionen

- S1** auf
- S2** ab
- S3** esc = Schritt zurück / Programmierung verlassen
- S4** ent = aktivieren / bestätigen
- S5** Reinigung



Einstieg in Diagnosemode

1. Maschine **AUS**
2. **S1 + S3 + S5** halten
3. Maschine **EIN**
4. Mit **S1** oder **S2** auf Diagnose und mit **S4** bestätigen
5. Mit **S1** oder **S2** auf Diagnoseparameter und mit **S4** bestätigen
6. Wert mit **S1** oder **S2** verändern und mit **S4** bestätigen

Diagnose

Displayanzeige	Werkspanometer	Min.	Max.
1 Kaffee lang N° Impulse 510	600	50	800
1 Espresso N° Impulse 194	195	50	800
1 Kaffee N° Impulse 360	360	50	800
Heizung Parameter K1 7	7	Nicht verstellen	Nicht verstellen
Heizung Parameter K2 30	30	Nicht verstellen	Nicht verstellen
Temp. normal °C 90	84 Heizung dickwandig V0.17+V0.25 88 Heizung dünnwandig V0.18-V0.24	70	130
Temp. hoch °C 96	86 Heizung dickwandig V0.17+V0.25 94 Heizung dünnwandig V0.18-V0.24	70	130
Temp. 1°Kaffee °C 98	88 Heizung dickwandig V0.17+V0.25 96 Heizung dünnwandig V0.18-V0.24	70	130
Temp. Dampf °C 120	120	70	150
Temp. Erhöhung °C 15	15	0	50
Satzzähler 0	0 Nicht editierbar	0	50

SOLIS AG SOLIS-Haus CH-8152 Glattbrugg	SOLIS Master 5000 Digital Diagnosemode 5000Digital_d 17.03.01 MIO	A	Seite 1 von 2
		11.06.02	

Displayanzeige	Werksparemeter	Min.	Max.
Satzstop 15	15	0	50
Total Wasser ml 92066	0 nicht editierbar	0	Milliarden 4
Wasser entkalk. ml 90373	0	0	Milliarden 4
Heisswasser Durchfl. L/h 20	20	Nicht verstellen	Nicht verstellen
Heisswasser Pumpenreg. 61330	61000 Automatische Einstellung	58000	65500
Wasserreserve N° Impulse 1900	0	0	
Maschinenstatus 32	32	Nicht verstellen	Nicht verstellen
Prod. Datum Tag 31	Produktions-Tag nicht editierbar	1	31
Prod. Datum Monat 10	Produktions- Monat nicht editierbar	1	12
Prod. Datum Jahr 2000	Produktions-Jahr nicht editierbar	1999	2050
Servicedatum Tag 31	Produktions-Tag editierbar	1	31
Servicedatum Monat 02	Produktions-Monat editierbar	1	12
Servicedatum Jahr 2001	Produktions-Jahr editierbar	1999	2050